



Spare Parts Catalog

MS-E 3060 II

Material number: 4472.098.200

Current date: 22.09.2017

ZF Friedrichshafen AG
Hauptverwaltung
80038 Friedrichshafen
Deutschland

Telefon: +49 7541 77-0

Telefax: +49 7541 77-908000

www.zf.com

zuständiges Werk:
Passau

Notes relating to the spare parts catalog

Setup of the spare parts catalog

- Cover sheet
- Technical Cover (only in SDM print)
- Overview of figures
- Figure
- Associated parts list
- Next figure
- Associated parts list
- ...

Figure and parts list



Overview of figures

Bildtafel Figure	Sachnummer Product number	Benennung (Description)	Technische Info Technical info	Description (Benennung)	Menge Quantity	Einheit Unit
068.08.17	1316.170.001	AUSLEGER	WL	SHIFT TURRET	1	Stk
068.08.06	1316.170.031	DECKEL	WL*H-H *VM	COVER	1	Stk
068.08.14	1316.170.808	DECKEL	WL*AUSL+GEH*H-H*HF160N	COVER	1	Stk
08	1316.170.441	ANSCHLUSSTEILE	WL*NG-VORB*RG-SCHL*168N *BAJONETT	CONNECTING PARTS	1	Stk

The "gap" indicates that there is no separate graphics panel (poster) for this assembly
The parts of this assembly are shown with the same mid-section number on the figure

1 Positions and subpositions

Pos.	Sachnummer Product number	Benennung (Description)	Technische Info Technical info	Description (Benennung)	Menge Quantity	Einheit Unit
0370	1315.201.054	RUECKLAUFBOLZEN	KPL.16S151*SG*L= 79	REV.IDLER SHAFT	1	Stk
/0120	0631.329.293	SPANNSTIFT		SLOT. PIN	1	Stk

Positions marked with "/" are the individual items of a completion
For example: Position 0370 contains a centering pin with the position /0120

2 Combinations with standardized parts

Pos.	Sachnummer Product number	Benennung (Description)	Technische Info Technical info	Description (Benennung)	Menge Quantity	Einheit Unit
0630		VERSCHL.SCHR.		SCREW PLUG	1	Stk
	0636.302.067	VERSCHL.SCHR.		SCREW PLUG	1	Stk
	0634.801.249	DICHTRING	A 26 X 31	SEALING RING	1	Stk

The parts list shows the components included in the combination of standardized parts

3 Depiction of position/item number on the figure and in the parts list

01.620 - on the figure 01 relates to the assembly in which the position is included. Due to program-related reasons, it is shown on the figure.

0620 - in the parts list

Pos.	Sachnummer Product number	Benennung (Description)	Technische Info Technical info	Description (Benennung)	Menge Quantity	Einheit Unit
0620	0732.040.736	DRUCKFEDER		COMPRESSION SPRING	1	Stk

4 *-Positions

Positions marked with an * are optional i.e. inclusion in the parts list is not mandatory.
The following note is shown on the figure

je nach Stücklistenausführung
depending on spec. number
*
suivant la nomenclature
secondo la distinta base

5 Parts, dotted display

Parts with dotted display on the figure are only used for orientation of other parts

Plant

Page 1 from 1

Material number: 4472.098.200

Plant: 447212502200

Material-assembly-group-no: 4472.125.022



MS-E 3060 II /
INPUT

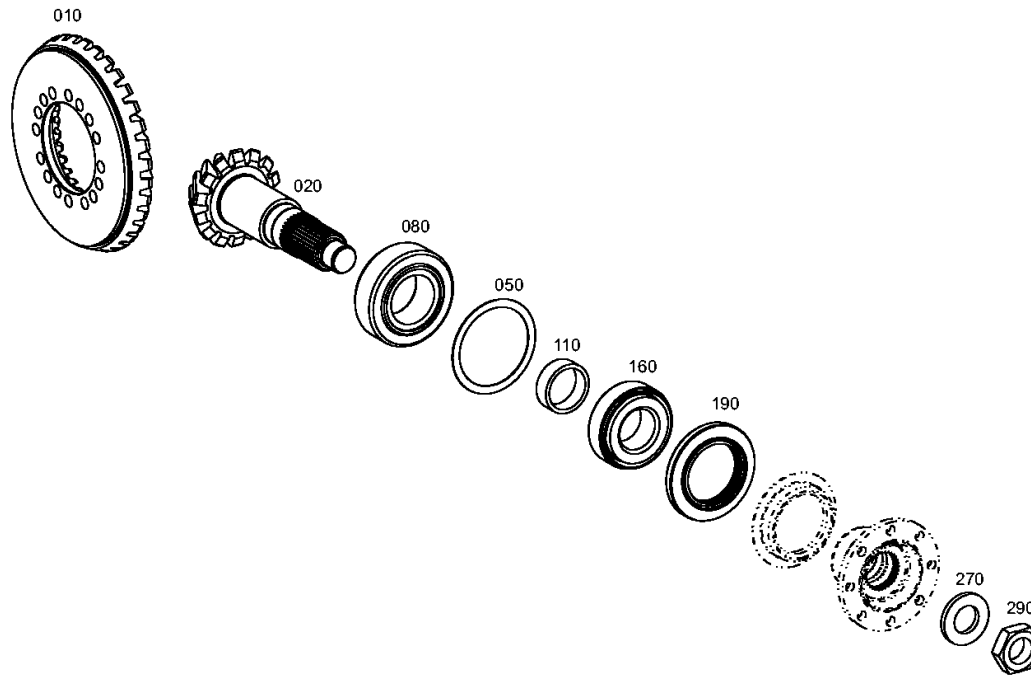

Plant

Page 1 from 1

Material number: 4472.098.200

Plant: 447212540500

Material-assembly-group-no: 4472.125.405



MS-E 3060 II /
INPUT

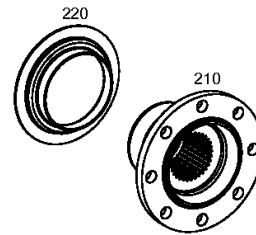

Plant

Page 1 from 2

Material number: 4472.098.200

Plant: 448203000100

Material-assembly-group-no: 4482.030.001



MS-E 3060 II /
DIFFERENTIAL

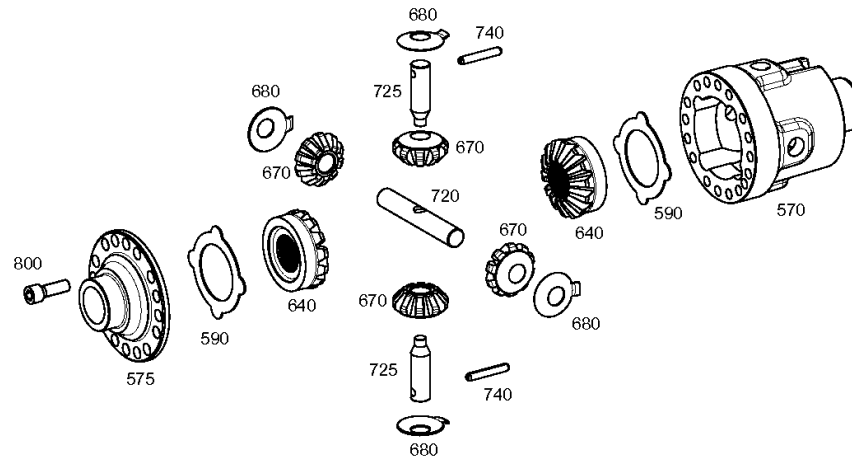

Plant

Page 2 from 2

Material number: 4472.098.200

Plant: 448203000150

Material-assembly-group-no: 4482.030.001



MS-E 3060 II /
DIFFERENTIAL

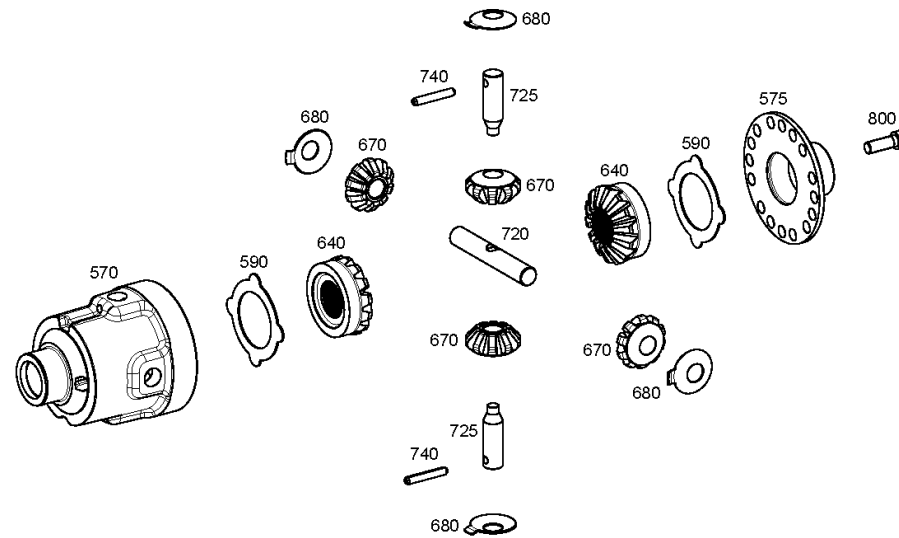

Plant

Page 1 from 1

Material number: 4472.098.200

Plant: 447212601100

Material-assembly-group-no: 4472.126.011



MS-E 3060 II /
AXLE CASING

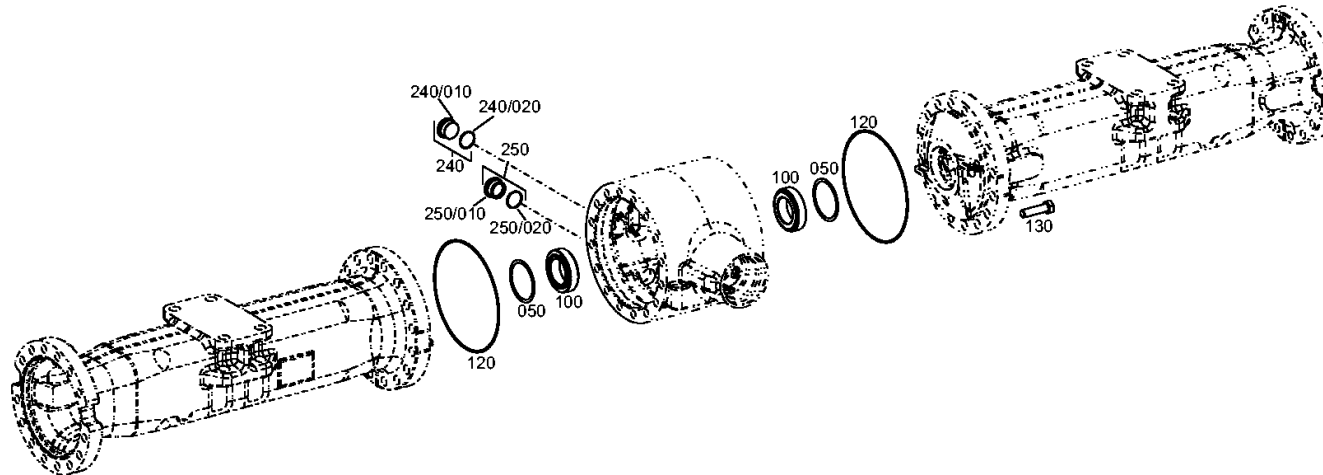

Plant

Page 1 from 1

Material number: 4472.098.200

Plant: 447212643600

Material-assembly-group-no: 4472.126.436



MS-E 3060 II /
AXLE CASING

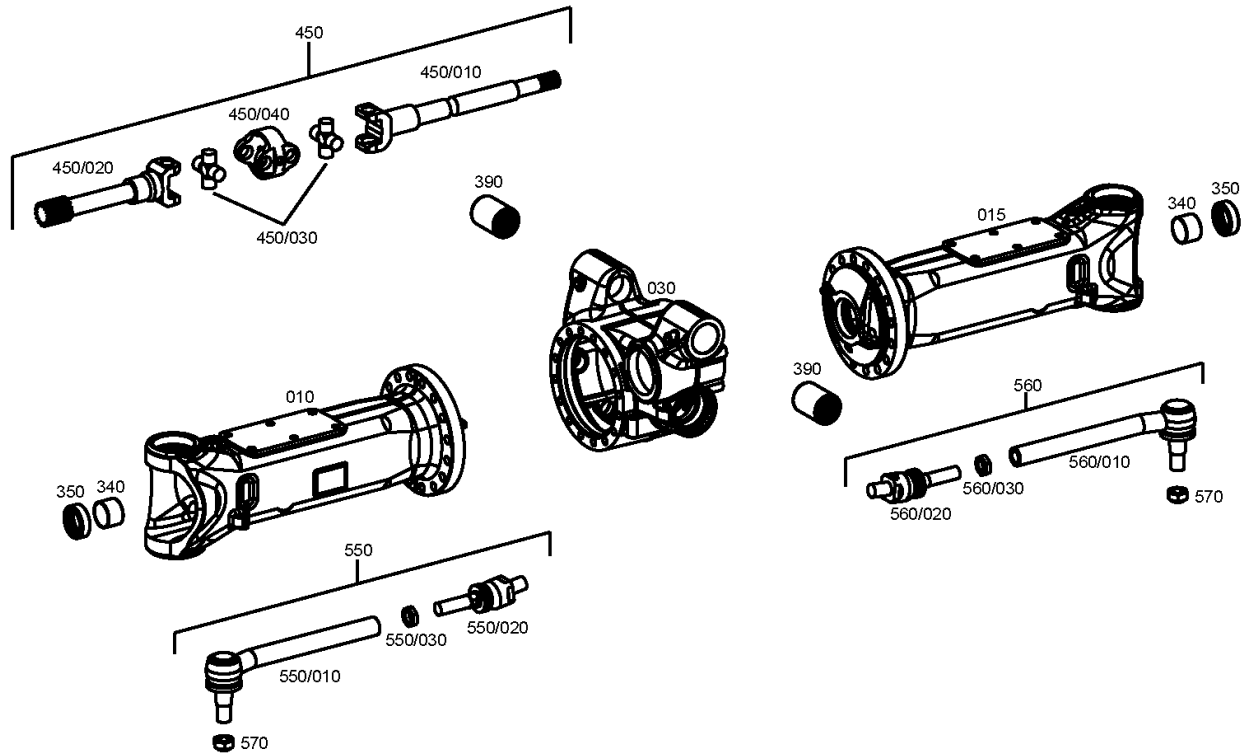

Plant

Page 1 from 1

Material number: 4472.098.200

Plant: 447212801900

Material-assembly-group-no: 4472.128.019



MS-E 3060 II /
JOINT HOUSING

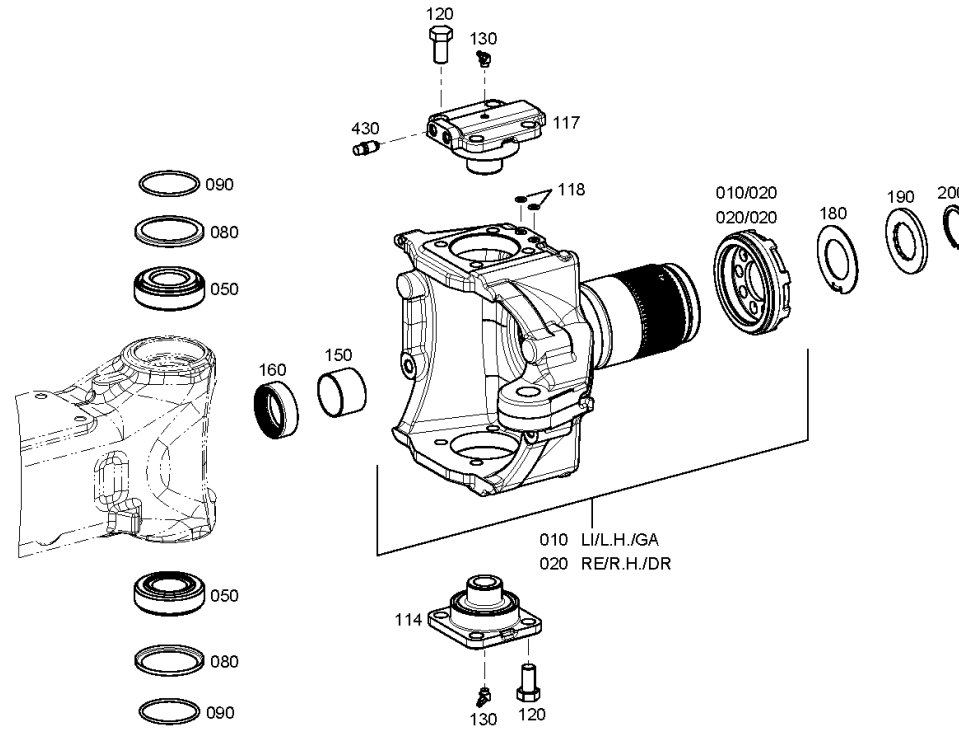

Plant

Page 1 from 1

Material number: 4472.098.200

Plant: 447212840000

Material-assembly-group-no: 4472.128.400



MS-E 3060 II /
JOINT HOUSING

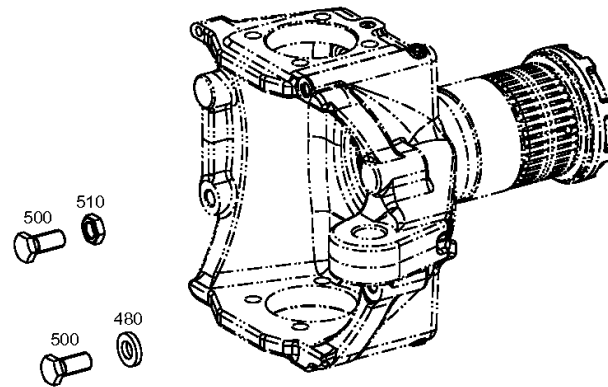

Plant

Page 1 from 1

Material number: 4472.098.200

Plant: 447213400200

Material-assembly-group-no: 4472.134.002



MS-E 3060 II /
STEERING

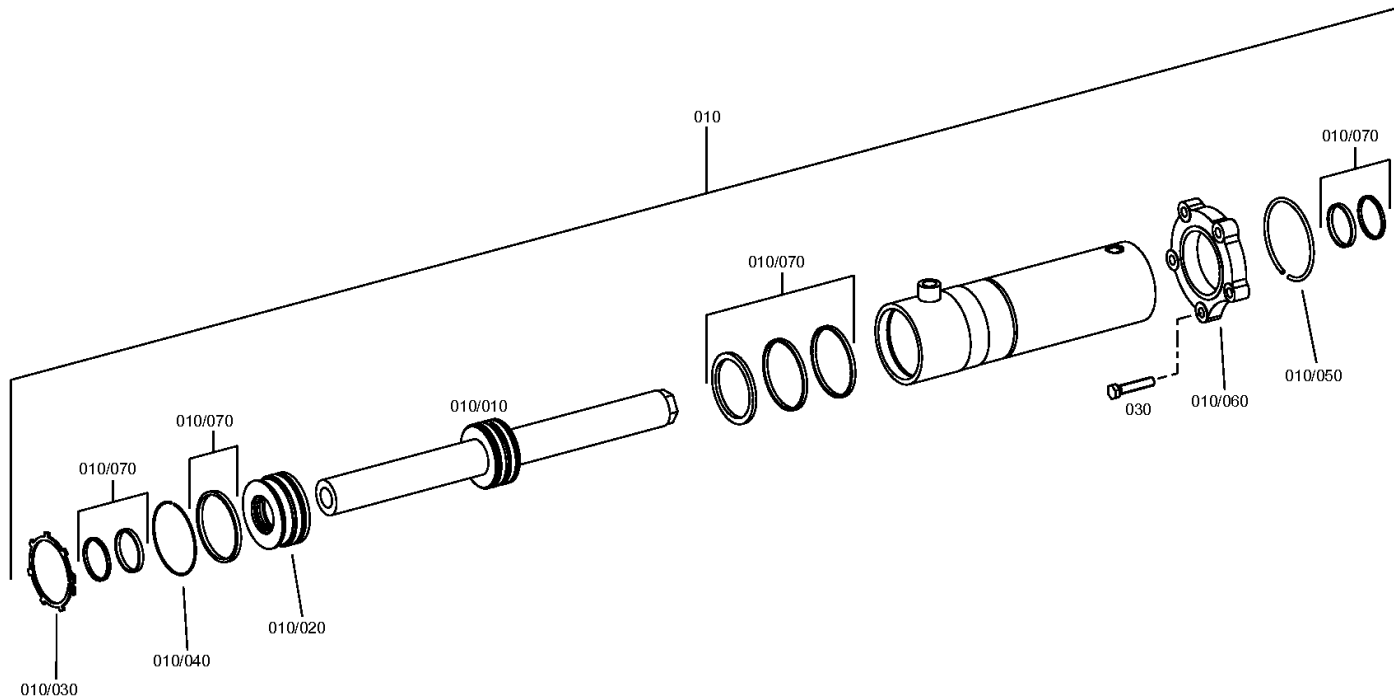

Plant

Page 1 from 1

Material number: 4472.098.200

Plant: 447213303700

Material-assembly-group-no: 4472.133.037



MS-E 3060 II /
OUTPUT

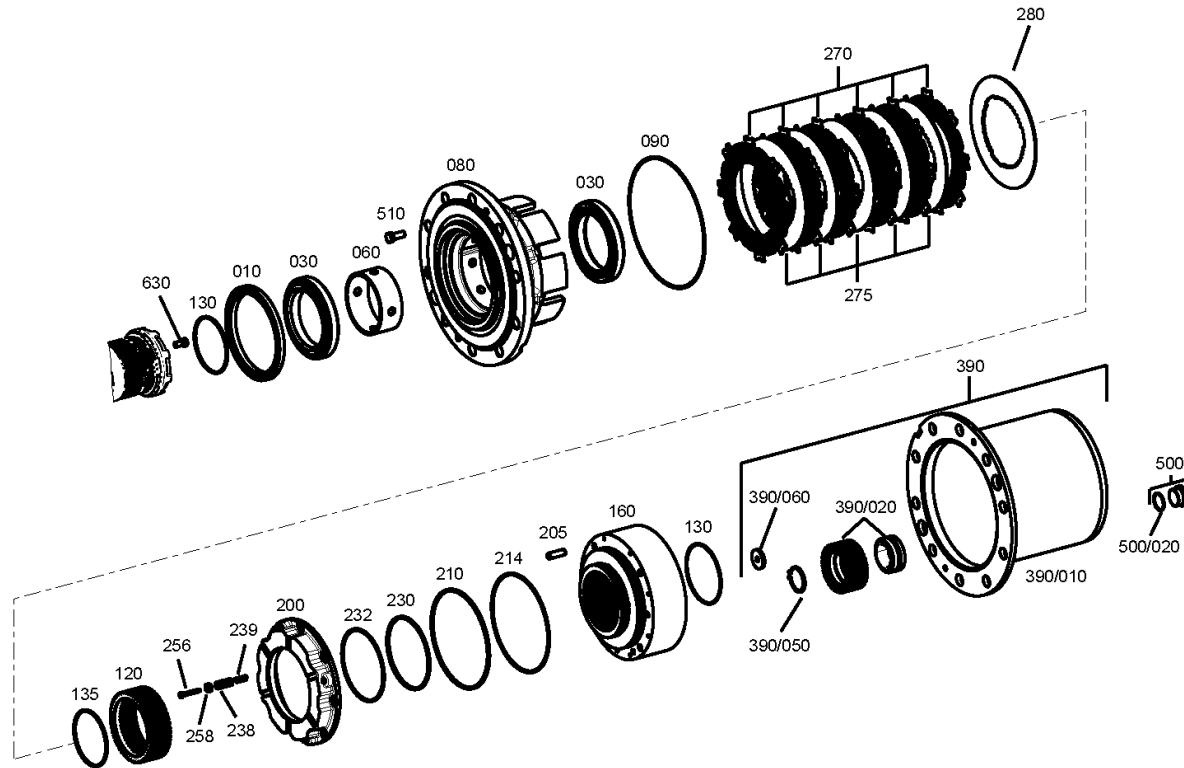

Plant

Page 1 from 1

Material number: 4472.098.200

Plant: 447213340700

Material-assembly-group-no: 4472.133.407



MS-E 3060 II /
OUTPUT

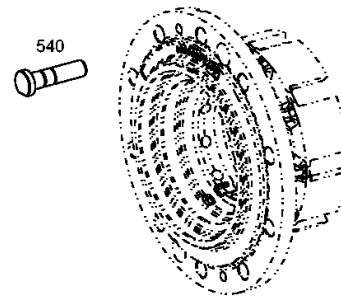

Plant

Page 1 from 1

Material number: 4472.098.200

Plant: 414313900200

Material-assembly-group-no: 4143.139.002



MS-E 3060 II /
TYPE PLATE

